



Lifting Gear Hire Corporation

P: 800.878.7305 | F: 708-430-3536 | www.lgh-usa.com | sales@lgh-usa.com

800 lbs Electric Winch

MYTE 300AB Capstan

Construction Features:

- Heavy-duty angle base drilled for four 1/2" bolt (9/16" mounting holes) with no welding required
- Fully sealed aluminum housings, with precision-cut gears, run in an oil bath
- Hardened steel worm and forged bronze worm gear holds load in position when stopped.
- Stress-proof drum shaft
- Frictionless bearings
- 286:1

Hoisting Rope:

Consult your local dealer for type and size of rope. Maintain at least three wraps of rope on capstan drum when in use. Heavier loads may require four wraps of rope.

Power:

- Universal 18,500 RPM reversible 1.25 HP brake motor (no-load speed)
- 15' power cord plugs into any 115 Volt AC grounded outlet
- 6 amp – No load
- 20 amp – Full load

Speeds:

- 59 FPM: No-load drum speed
- 30 FPM: 500 lbs

Duty Cycle:

- 25% – 15 min/hr when operating at full load.

Shipping Weight: 69 lbs

Factory-Installed Options:

- Foot switch
- 230 Volt
- Pole mount
- Swivel mount
- Variable speed
- Receiver hitch mount



FRONT VIEW

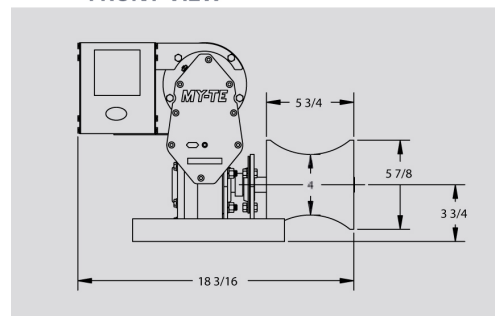

SIDE VIEW

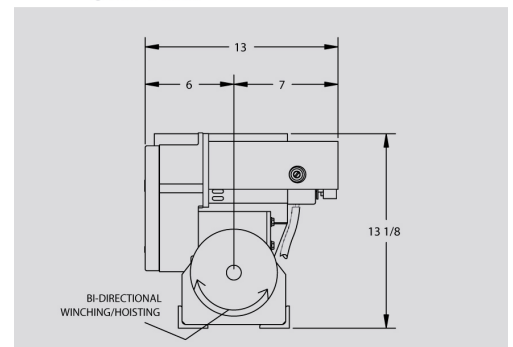

TOP VIEW

