



Lifting Gear Hire Corporation

Phone: 800-878-7305 Fax: 708-430-3536

www.lgh-usa.com

4,000 lbs. Capacity Air Winch (HUL-40)

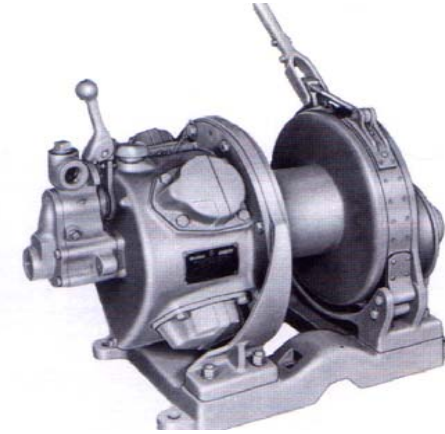

Winch Model:	HUL-40	Manufacture:	Ingersoll Rand
Line Pull (lbs.)	4,000	Weight (lbs.):	600 (No Cable)
(Nominal Capacity)		Line Speed (fpm)	70
Wire Rope Dia.. (in.)	1/2", 3/8", 7/16"	Drum Root Dia:	7"
Rope Anchor Hole Dia.:	11/16"	Motor HP:	11
Full Drum Capacity	813' (1/2" wire rope)	Avg. CFM Required:	175
	1012' (7/16" wire rope)	Drum Length	15 3/16"
	1445' (3/8" wire rope)	Max Stall Pull (lbs.)	9,000
		(First Layer @90 PSI)	

** Recommended working length is 80% rope capac

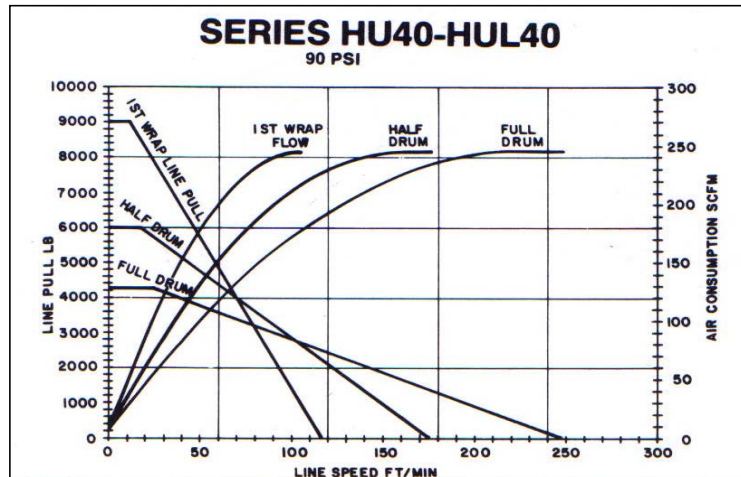

Dimensions:	
A	40 11/16"
B	15 3/16"
C	30 3/8"
D	1 NPT

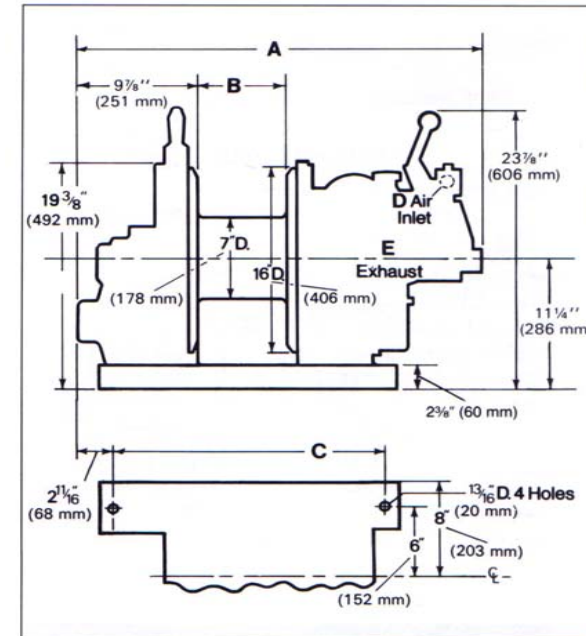
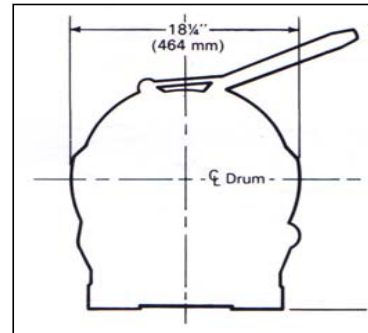

Wire Rope Storage Capacities

3/8" - 1445'	Cable Strength 13,120 lbs.
7/16" - 1012'	Cable Strength 17,800 lbs.
1/2" - 813'	Cable Strength 23,000 lbs.

** NOTE: Cable Strength is the Breaking Strength.
The Recommended safety factor for wire rope is;
Pulling - 3.5:1 Lifting - 5.0:1

** Nominal capacity rating complies with ANSI B30.7 for Base Mounted Drum Hoists. Provides 5:1 design factor based on the rated line pull.



LIFTING GEAR HIRE CORPORATION

PHONE: 800-878-7305 | FAX:708-430-3536 | www.lgh-usa.com

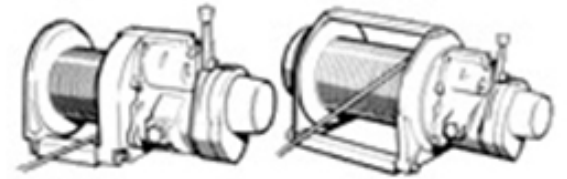

Wire Rope Selections for Winches *Lifting vs. Pulling*

Wire Rope Selection				
Rope Size (in.)	ⓈBreaking Strength in		Recommended Safe Working Load (lbs.)	
	2000 lb. tons	Wt./Ft. (lbs.)	Pulling 3.5:1 [Ⓢ]	Lifting/Lowering 5.0:1 [Ⓢ]
1/4 (0.25)	2.94	0.11	1,680	1,176
5/16 (0.31)	4.58	0.18	2,616	1,832
3/8 (0.38)	6.56	0.26	3,748	2,624
7/16 (0.44)	8.89	0.35	5,080	3,556
1/2 (0.50)	11.50	0.46	6,570	4,600
5/8 (0.63)	17.90	0.72	10,228	7,160
3/4 (0.75)	25.60	1.04	14,628	10,240
7/8 (0.88)	34.60	1.42	19,771	13,840
1 (1.00)	44.90	1.85	25,657	17,960
1 1/8 (1.125)	56.50	2.34	32,286	22,600

*Nominal capacity rating complies with ANSI 830.7 for Base Mounted Drum Hoists. Provides 5:1 design factor based on the rated line pull.

*Based on improved plow steel wire rope with independent wire core, except HSU models which require extra improved plow steel.

*Regarding ropes, ANSI 830. requires a minimum of 3:5:1 origin factor with 15:1 rope pitch diameter to drum diameter for most winching applications (e.g. pulling/hauling and anchor handling). For lifting and lowering a 5:1 design factor with an 18:1 rope pitch diameter to drum diameter is required.

*Extra improved plow steel IWRC wire rope.