



Lifting Gear Hire Corporation

Phone: 800-878-7305 Fax: 708-430-3536

www.lgh-usa.com

3,000 lbs. Capacity Air Winch (H5U)

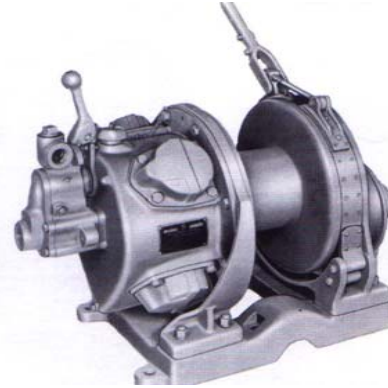

Winch Model:	H5U	Manufacture:	Ingersoll Rand
Line Pull (lbs.)	3,000	Weight (lbs.):	525 (No Cable)
(Nominal Capacity)		Line Speed (fpm)	150
Wire Rope Dia.. (in.)	1/2", 3/8", 7/16"	Drum Root Dia:	7"
Rope Anchor Hole Dia.:	11/16"	Motor HP:	14
Full Drum Capacity	379' (1/2" wire rope)	Avg. CFM Required:	290
	476' (7/16" wire rope)	Drum Length	7 1/8"
	686' (3/8" wire rope)	Max Stall Pull (lbs.)	7,800
		(First Layer @90 PSI)	

** Recommended working length is 80% rope capacity

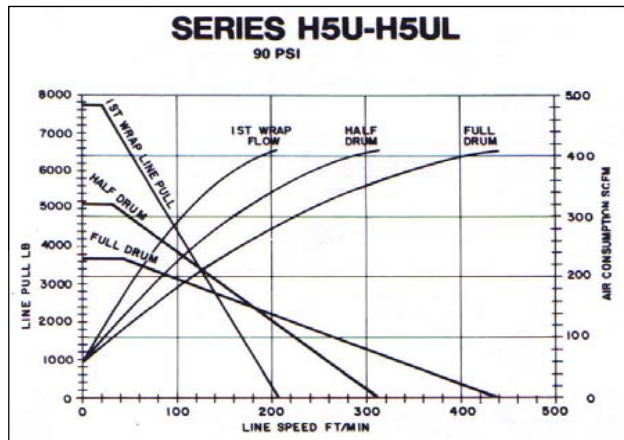

Dimensions:	
A	32 7/8"
B	7 1/8"
C	22 5/16"
D	1.25 NPT

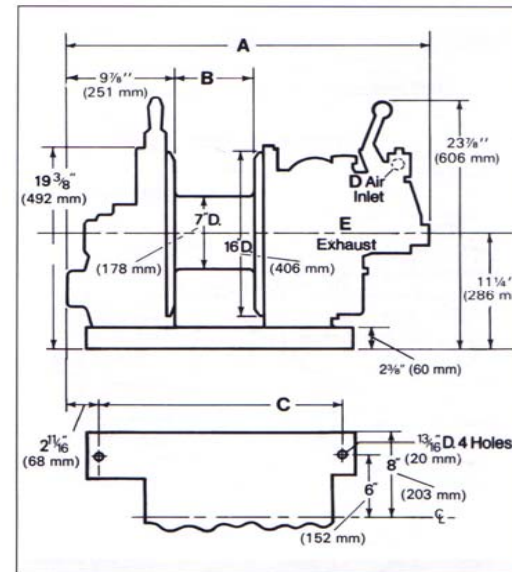
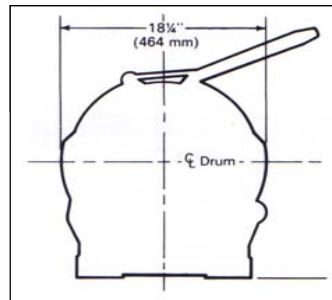

Wire Rope Storage Capacities

3/8" - 686'	Cable Strength 13,120 lbs.
7/16" - 476'	Cable Strength 17,800 lbs.
1/2" - 379'	Cable Strength 23,000 lbs.

** NOTE: Cable Strength is the Breaking Strength.

The Recommended safety factor for wire rope is;

Pulling - 3.5:1 Lifting - 5.0:1

This model Air Winch may be equipped with disengaging clutch. Please reference Ingersoll Rand parts bulletin form 5918 edition 8 June 1979 page 10 warning disengaging clutch parts: Operation of the motor with the clutch disengaged while holding a suspended load will allow the load to drop.



LIFTING GEAR HIRE CORPORATION

PHONE: 800-878-7305 | FAX:708-430-3536 | www.lgh-usa.com

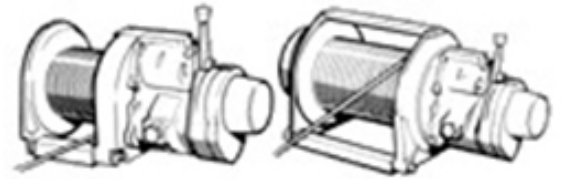

Wire Rope Selections for Winches *Lifting vs. Pulling*

Wire Rope Selection				
Rope Size (in.)	ⓈBreaking Strength in		Recommended Safe Working Load (lbs.)	
	2000 lb. tons	Wt./Ft. (lbs.)	Pulling 3.5:1 [Ⓢ]	Lifting/Lowering 5.0:1 [Ⓢ]
1/4 (0.25)	2.94	0.11	1,680	1,176
5/16 (0.31)	4.58	0.18	2,616	1,832
3/8 (0.38)	6.56	0.26	3,748	2,624
7/16 (0.44)	8.89	0.35	5,080	3,556
1/2 (0.50)	11.50	0.46	6,570	4,600
5/8 (0.63)	17.90	0.72	10,228	7,160
3/4 (0.75)	25.60	1.04	14,628	10,240
7/8 (0.88)	34.60	1.42	19,771	13,840
1 (1.00)	44.90	1.85	25,657	17,960
1 1/8 (1.125)	56.50	2.34	32,286	22,600

*Nominal capacity rating complies with ANSI 830.7 for Base Mounted Drum Hoists. Provides 5:1 design factor based on the rated line pull.

*Based on improved plow steel wire rope with independent wire core, except HSU models which require extra improved plow steel.

*Regarding ropes, ANSI 830. requires a minimum of 3:5:1 origin factor with 15:1 rope pitch diameter to drum diameter for most winching applications (e.g. pulling/hauling and anchor handling). For lifting and lowering a 5:1 design factor with an 18:1 rope pitch diameter to drum diameter is required.

*Extra improved plow steel IWRC wire rope.