



LIFTING GEAR HIRE CORPORATION

PHONE: 800-878-7305 FAX: 708-430-3536

www.lgh-usa.com

5 TON HAND CHAIN HOIST

DUFF LYNX LHH-5B

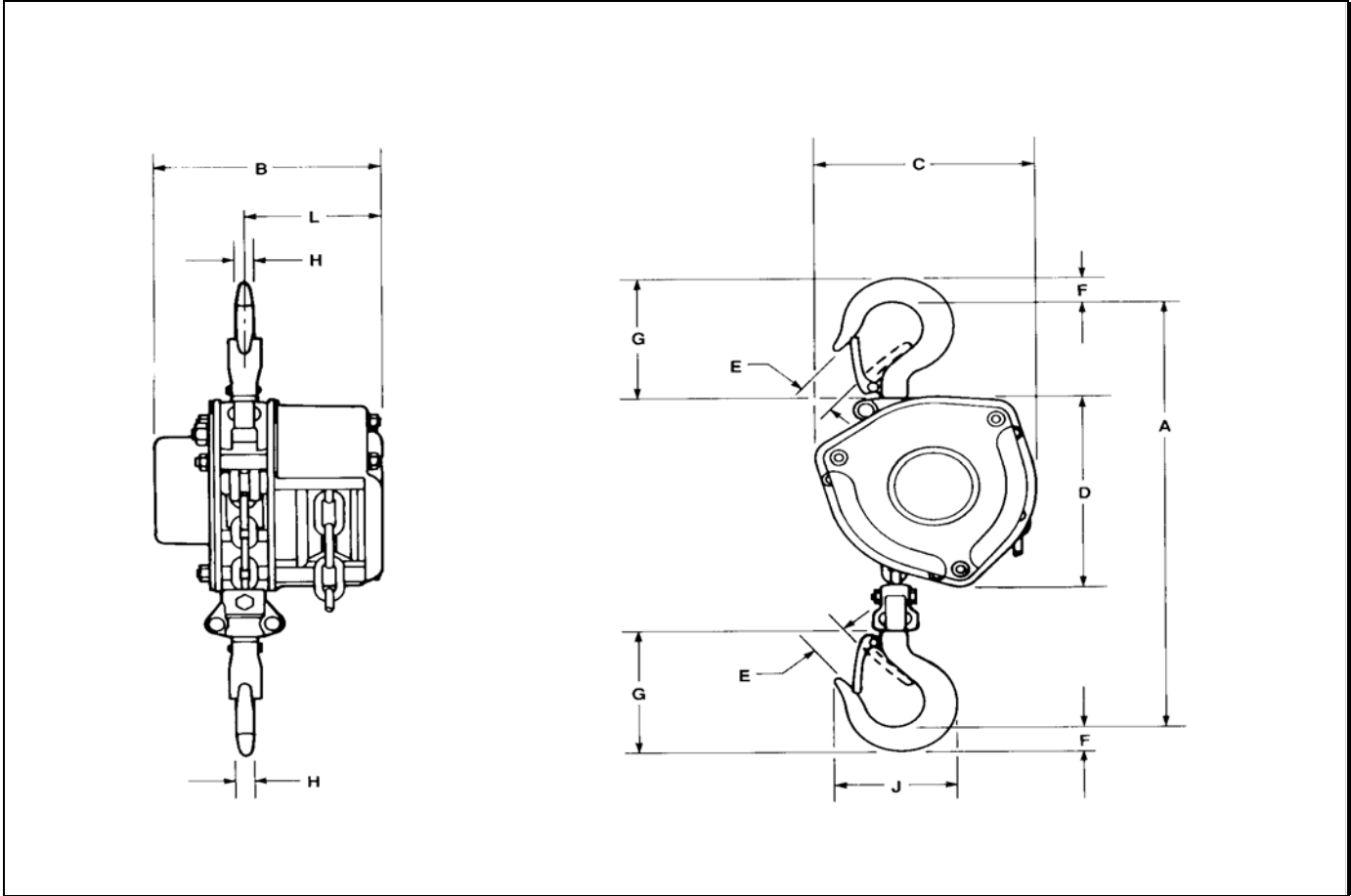

HOIST DIMENSIONS (in.)

A	B	C	D	E	F	G	H	J	L	No. of load chain / Size
22.62"	6.50"	11.1"	7.3"	1.87"	1.8"	6.78"	1.33"	6.5"	3.54"	3 / 7.9 X 21.2 mm

HOIST SPECIFICATIONS

Rated Load	Weight with	Minimum Distance	Chain Pull to Lift	Hook
Throat (lbs.) 10,000	(10' h.o.l.) 77 # (1.5 lbs. per extra foot h.o.l.)	Between Hooks (in.) 22 5/8"	Rated Load (lbs.) 79	Opening (in.) 1 7/8"