



**LIFTING GEAR HIRE CORPORATION**

PHONE: 800-878-7305 FAX: 708-430-3536

www.lgh-usa.com

**3 TON HAND CHAIN HOIST**

**DUFF LYNX LHH-3B**

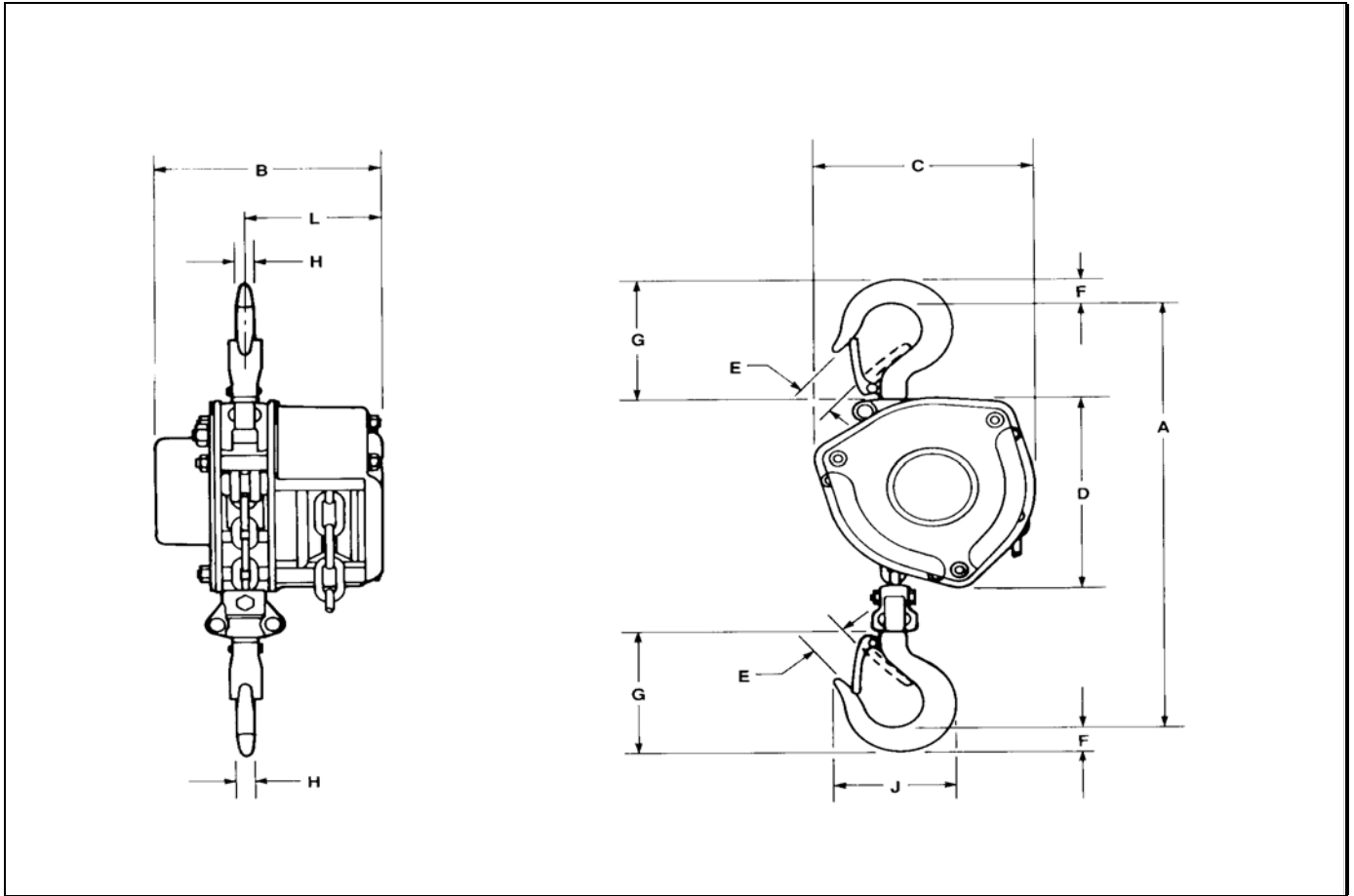

**HOIST DIMENSIONS (in.)**

A	B	C	D	E	F	G	H	J	L	No. of load chain / Size
17.12"	7.81"	10"	10"	1.56"	1.5"	5.75"	1.10"	5.43"	4.17"	1 / 10 X 30.2 mm

**HOIST SPECIFICATIONS**

Rated Load	Weight with	Minimum Distance	Chain Pull to Lift	Hook
(lbs.)	(10' h.o.l.)	Between Hooks (in.)	Rated Load (lbs.)	Opening (in.)
6000	68 # (1.5 lbs per extra foot h.o.l.)	17 1/8"	84	1 9/16"