



**LIFTING GEAR HIRE CORPORATION**

PHONE: 800-878-7305 FAX: 708-430-3536

www.lgh-usa.com

**2 TON HAND CHAIN HOIST**

**DUFF LYNX LHH-2B**

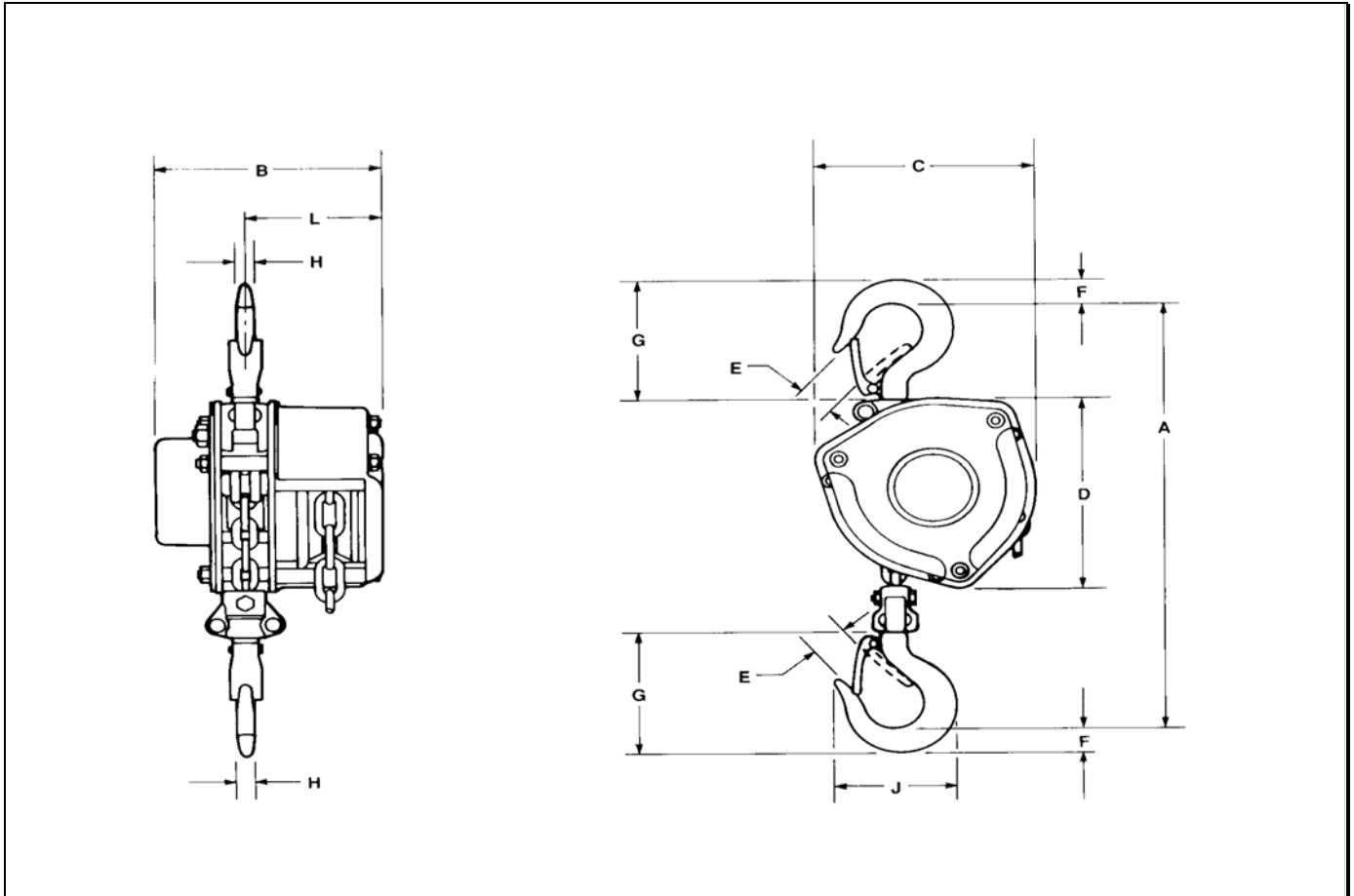

**HOIST DIMENSIONS (in.)**

A	B	C	D	E	F	G	H	J	L	No. of load chain / Size
15"	7.21"	8.44"	8.5"	1.38"	1.22"	4.93"	.88"	4.56"	3.85"	1 / 7.9 X 24.2 mm

**HOIST SPECIFICATIONS**

Rated Load	Weight with	Minimum Distance	Chain Pull to Lift	Hook
Throat (lbs.) 4000	(10' h.o.l.) 46 # (1 lbs per extra foot h.o.l.)	Between Hooks (in.) 15"	Rated Load (lbs.) 88	Opening (in.) 1 1/2"