



**LIFTING GEAR HIRE CORPORATION**

PHONE: 800-878-7305 FAX: 708-430-3536

www.lgh-usa.com

**1 TON HAND CHAIN HOIST**

**DUFF LYNX LHH-1B**

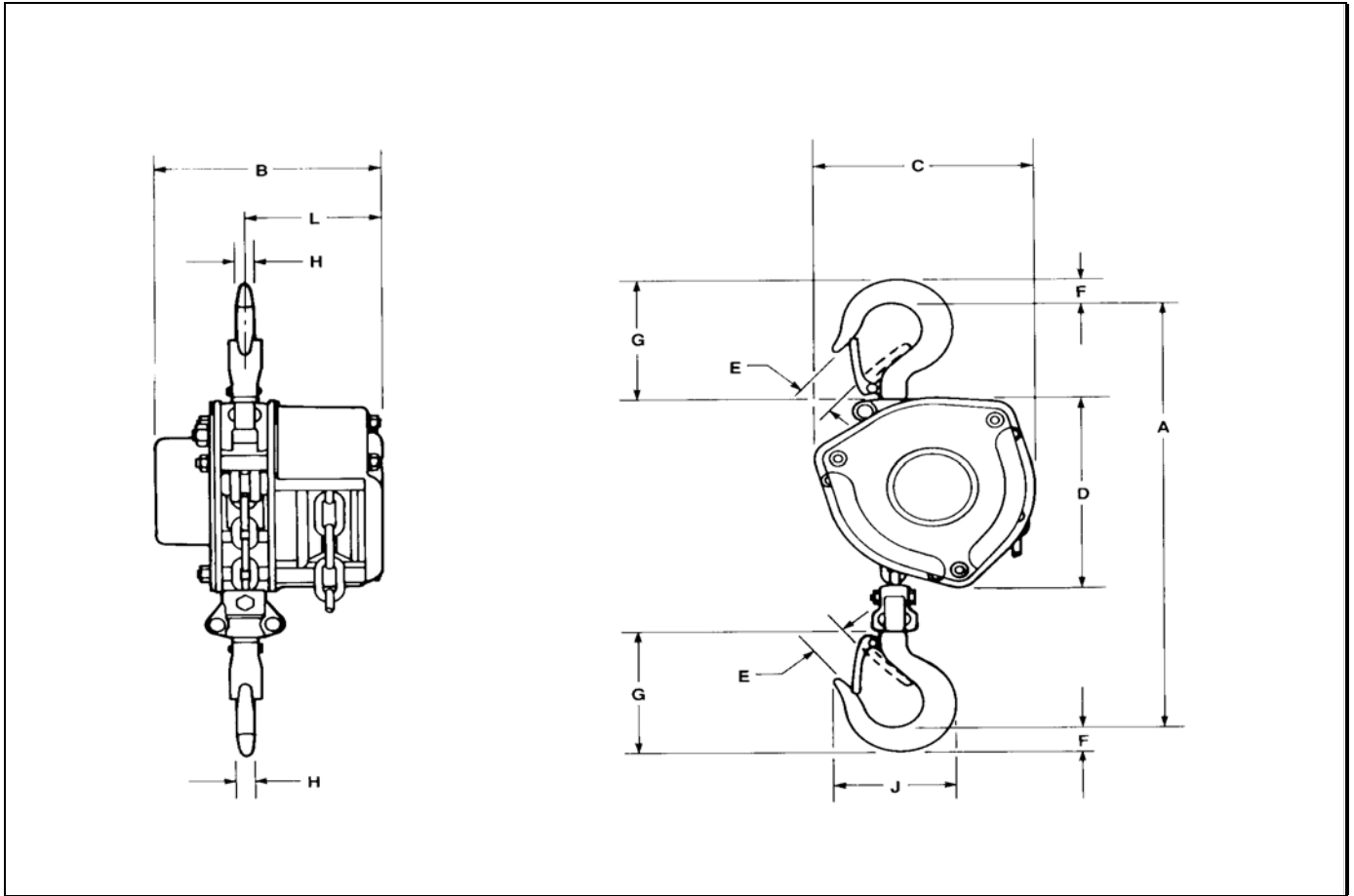

**HOIST DIMENSIONS (in.)**

A	B	C	D	E	F	G	H	J	L	No. of load chain / Size
11.81"	5.93"	6.25"	6"	1.12"	.89"	4.03"	.62"	3.59"	3.42"	1 / 6.3 X 19.1 mm

**HOIST SPECIFICATIONS**

Rated Load	Weight with	Minimum Distance	Chain Pull to Lift	Hook
(lbs.)	(10' h.o.l.)	Between Hooks (in.)	Rated Load (lbs.)	Opening (in.)
2000	25 # (.7 lbs per extra foot h.o.l.)	11 13/16"	60	1 1/8"