



LIFTING GEAR HIRE CORPORATION

PHONE: 800-878-7305

FAX: 708-430-3536

www.lgh-usa.com

15 TON HAND CHAIN HOIST YALE SHA-15

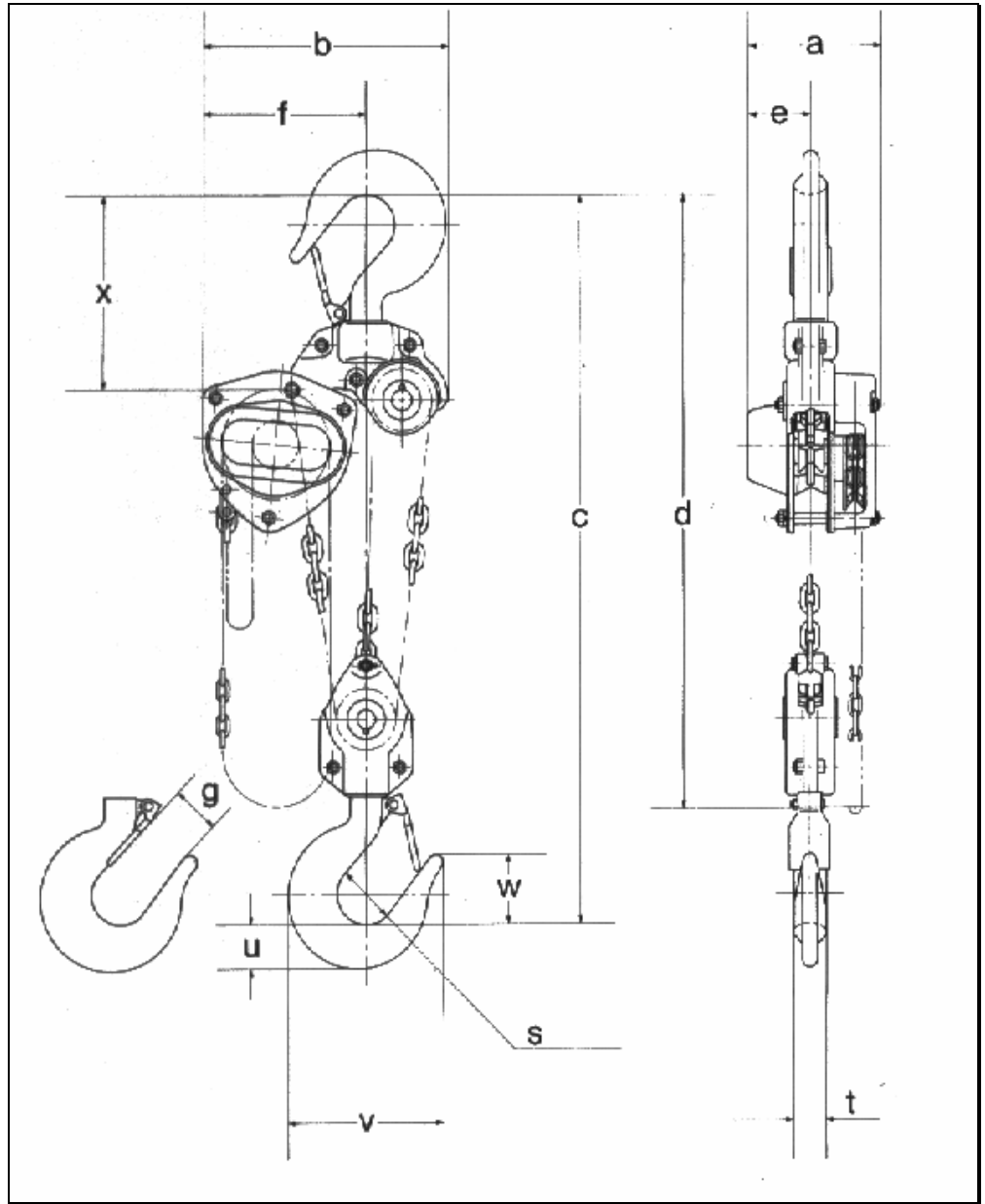

HOIST DIMENSIONS (in.)

A	B	C	S	E	U	G	T	V	W	No. of load chain / Size
7.81"	20.31"	50.62"	-	4.18"	2.84"	2.93"	2.43"	10.68"	-	5 / 10 X 30.3 mm

HOIST SPECIFICATIONS

Rated Load	Weight with	Minimum Distance	Chain Pull to Lift	Hook
Throat (lbs.) 30000	(10' h.o.l.) 341# (10 lbs. per extra foot h.o.l.)	Between Hooks (in.) 50 5/8"	Rated Load (lbs.) 103	Opening (in.) 2 15/16"