



LIFTING GEAR HIRE CORPORATION

PHONE: 800-878-7305

FAX: 708-430-3536

www.lgh-usa.com

**5 TON
ELECTRIC
CHAIN HOIST
HARRINGTON
ES050S**

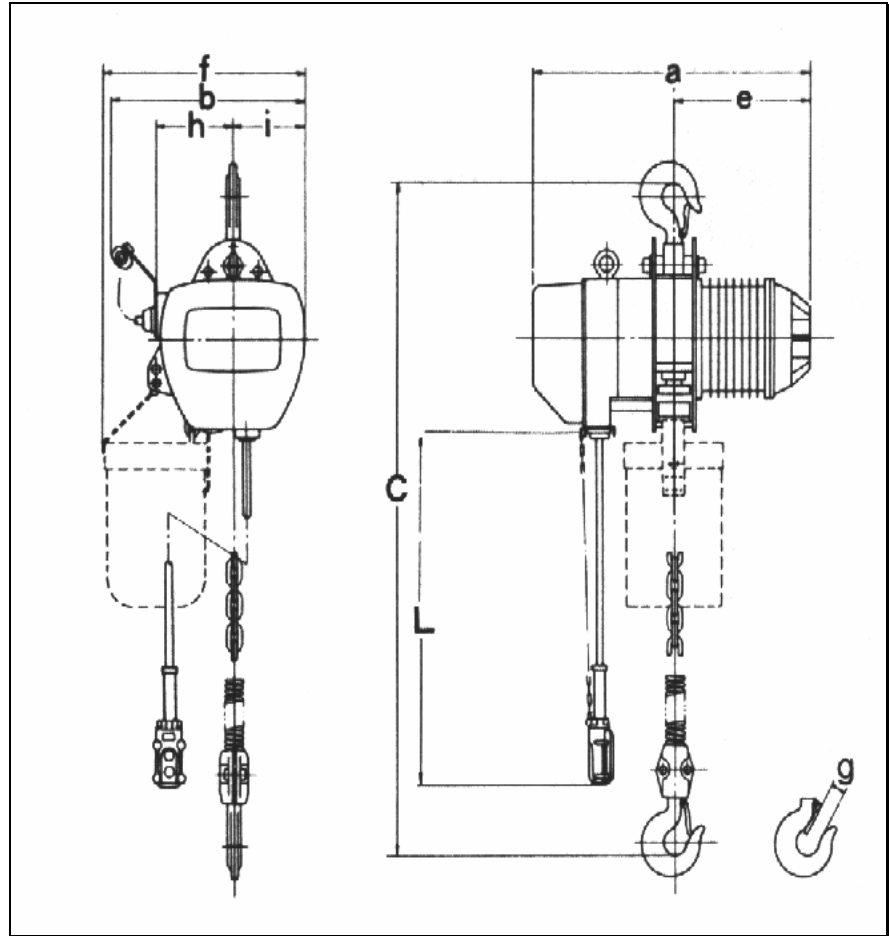

HOIST DIMENSIONS (in.)

a	b	e	f	g	h	i	C	No. of load chain / Size
24"	18.5"	12"	18.5"	1.8"	11"	4"	36.6"	2 / 11.2 X 34.4 mm

HOIST SPECIFICATIONS

Rated Load (lbs.)	Weight with (10' h.o.l.)	Minimum Distance Between Hooks (in.)
10000	298#	36.6"
(3.64 lbs. per extra foot h.o.l.)		

Lifting Motor 3 phase (230 or 460 V)

Rated Current (amps)

Lifting Speed

Out-Put HP | Duty Rating Min

230 | 460

4

40

15.6

7.8

10.5 FPM