



LIFTING GEAR HIRE CORPORATION

PHONE: 800-878-7305

FAX: 708-430-3536

www.lgh-usa.com

**3 TON
ELECTRIC
CHAIN HOIST
HARRINGTON
ES030S**

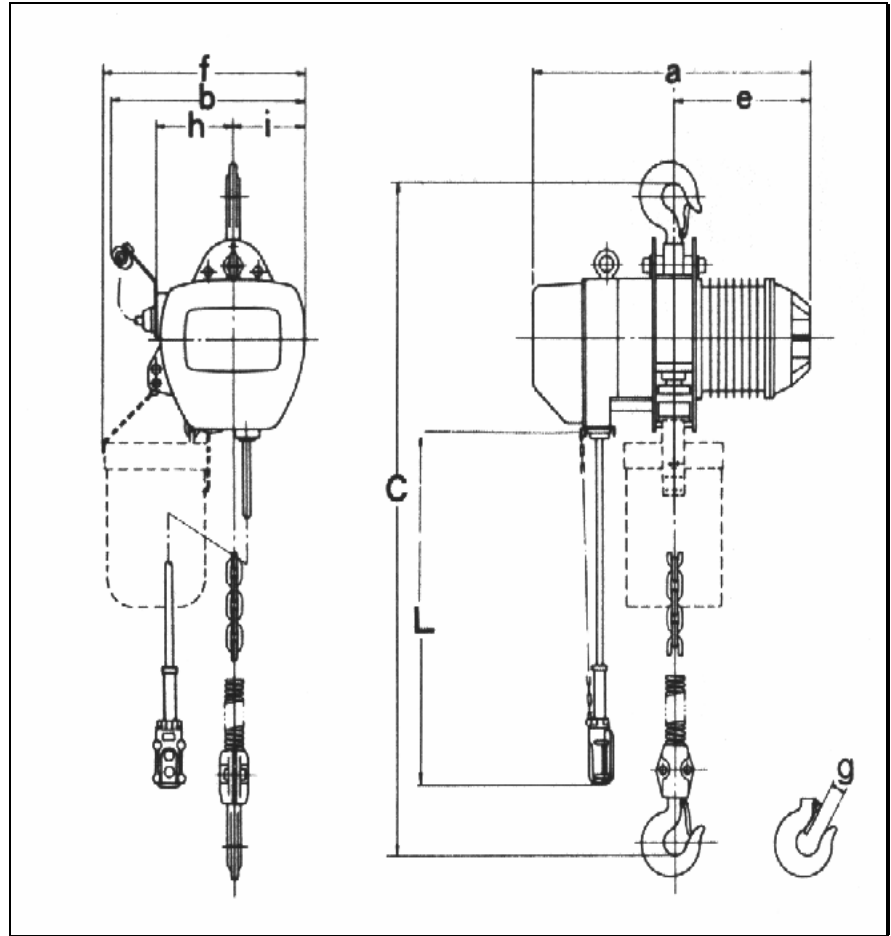

HOIST DIMENSIONS (in.)

a	b	e	f	g	h	i	C	No. of load chain / Size
24"	18.5"	12"	18.5"	1.7"	10.5"	4"	35.2"	2 / 10 X 30.2 mm

HOIST SPECIFICATIONS

Rated Load (lbs.)	Weight with (10' h.o.l.)	Minimum Distance Between Hooks (in.)
6000	278#	35.2"
(3.3 lbs per extra foot h.o.l.)		

<u>Lifting Motor 3 phase (230 or 460 V)</u>	<u>Rated Current (amps)</u>	<u>Lifting Speed</u>
Out-Put HP Duty Rating Min	230 460	
4 40	15.6 7.8	17 FPM