



LIFTING GEAR HIRE CORPORATION

PHONE: 800-878-7305

FAX: 708-430-3536

www.lgh-usa.com

**2.5 TON
ELECTRIC
CHAIN HOIST
HARRINGTON
ES025S**

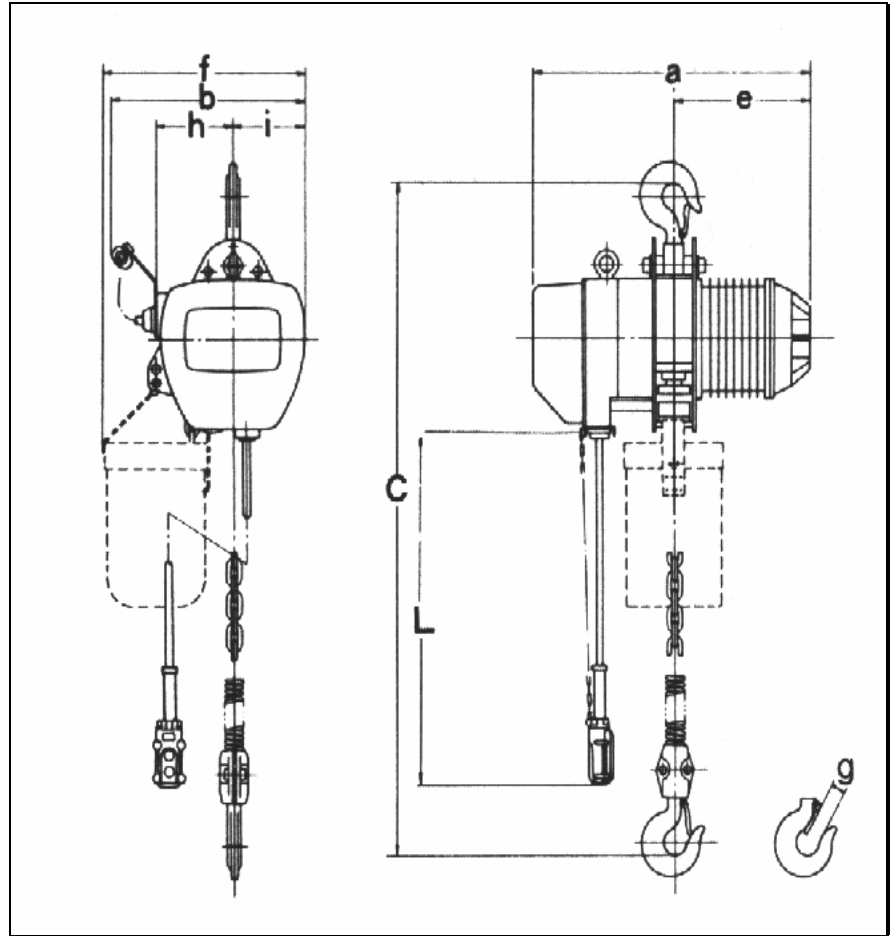

HOIST DIMENSIONS (in.)

a	b	e	f	g	h	i	C	No. of load chain / Size
24"	18.5"	12"	18.5"	1.8"	11"	4"	36.6"	1 / 11.2 X 34.4 mm

HOIST SPECIFICATIONS

Rated Load (lbs.)	Weight with (10' h.o.l.)	Minimum Distance Between Hooks (in.)
5000	215#	29.5"
(1.82 lbs per extra foot h.o.l.)		

<u>Lifting Motor 3 phase (230 or 460 V)</u>	<u>Rated Current (amps)</u>	<u>Lifting Speed</u>
Out-Put HP Duty Rating Min	230 460	
4 40	15.6 7.8	10.5 FPM