

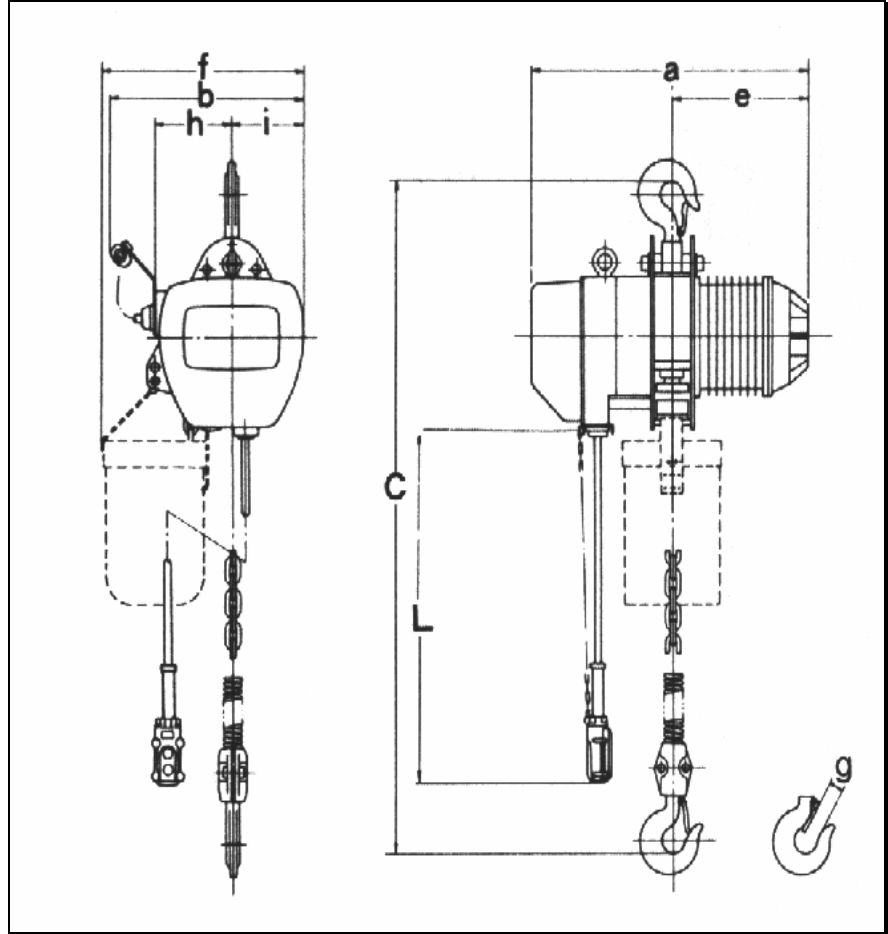

**LIFTING GEAR HIRE CORPORATION**

**PHONE: 800-878-7305**  
**FAX: 708-430-3536**  
**www.lgh-usa.com**

**1.5 TON  
 ELECTRIC  
 CHAIN HOIST  
 HARRINGTON  
 ES015S**



**HOIST DIMENSIONS (in.)**

a	b	e	f	g	h	i	C	No. of load chain / Size
24"	18.5"	12"	18.5"	1.3"	8.5"	6"	28.5"	1 / 10 X 30.2 mm

**HOIST SPECIFICATIONS**

Rated Load (lbs.)	Weight with (10' h.o.l.)	Minimum Distance Between Hooks (in.)
3000	242#	28.5"
( 1.5 lbs per extra foot h.o.l.)		

<u>Lifting Motor 3 phase (230 or 460 V)</u>	<u>Rated Current (amps)</u>	<u>Lifting Speed</u>
Out-Put HP   Duty Rating Min	230   460	
4   40	15.6   7.8	35 FPM