

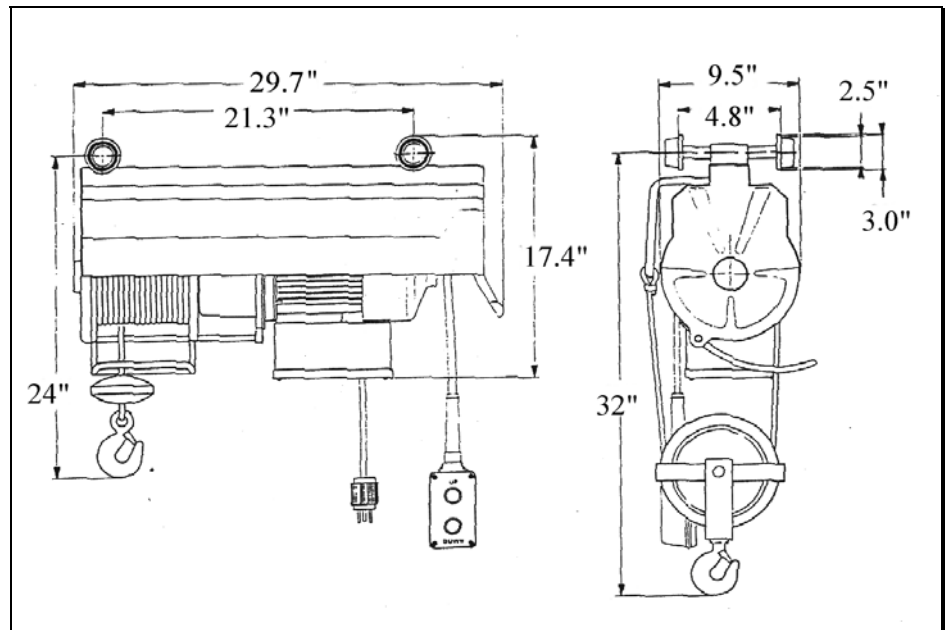

LIFTING GEAR HIRE CORPORATION

PHONE: 800-878-7305
FAX: 708-430-3536
www.lgh-usa.com

600 / 1200 LBS.
BUILDERS
HOIST
BETAMAX
GEMINI PLUS

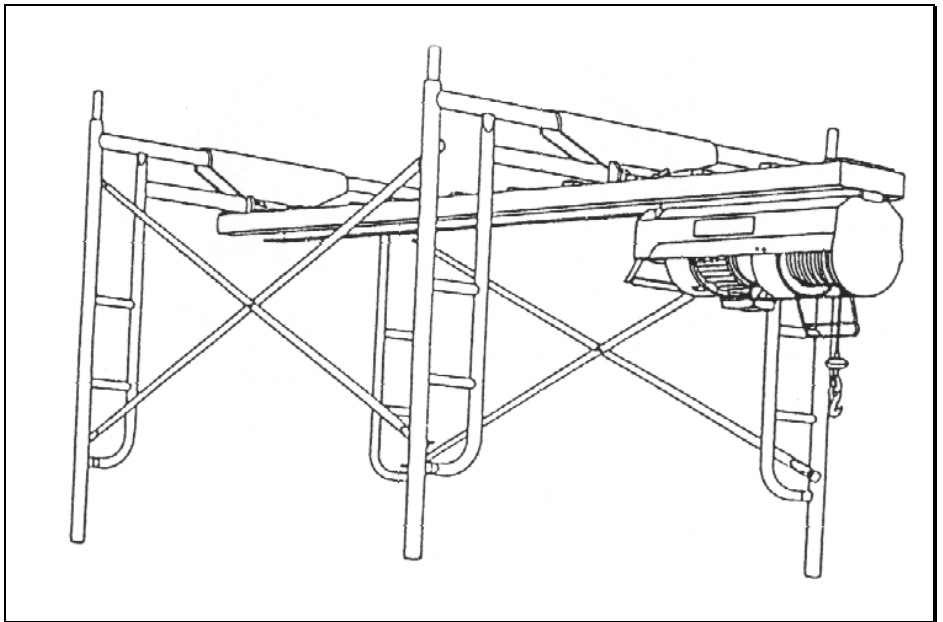

BUILDERS HOIST SPECIFICATIONS

| | | | | |
|------------------------------------|--------------------------------------|--|------------------------------------|-----------------------------|
| Rated Load (lbs.) 600 / 1200 | Hoisting Speed (fpm) 80' / 40' | Maximum Cable Supplied (1/4") 160' | Scaff Trac Weight 135 lbs. | Hoist Weight 135 lbs. |
| AC Power 220 Volt / 10 AMP | Boom Overhang 3.5' | No. of Lines 1 / 2 | Counterweight Req. 600# / 1200# | |