

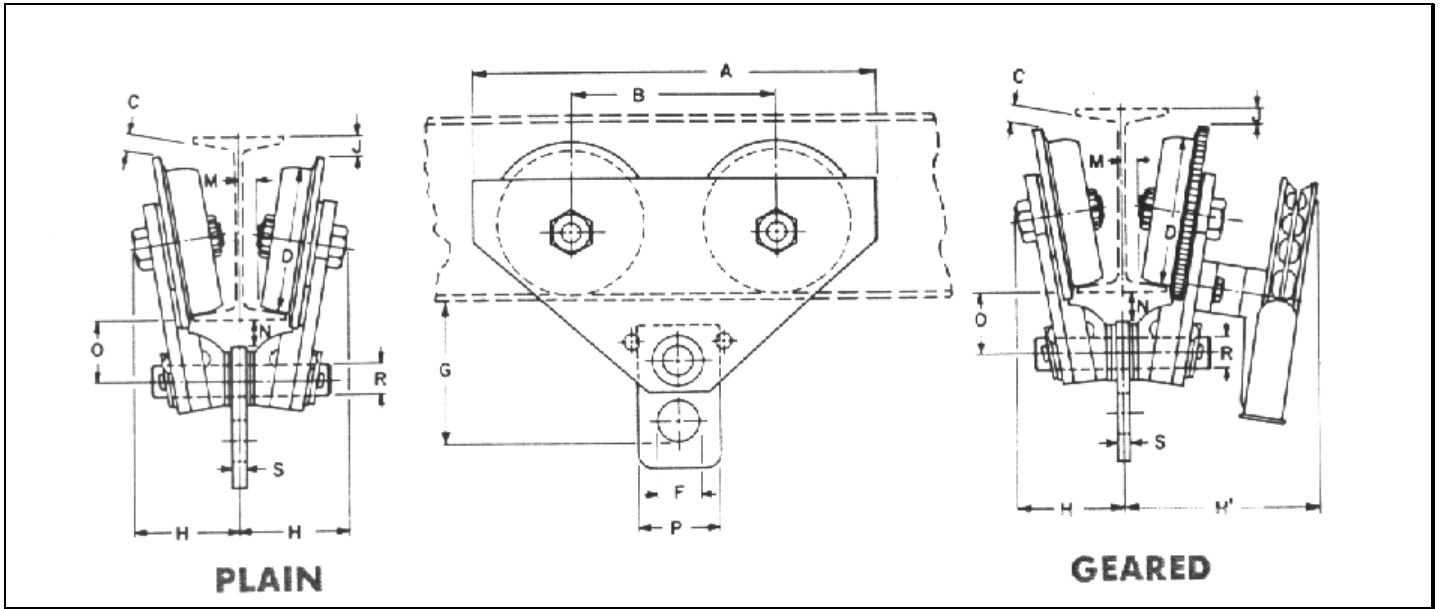

LIFTING GEAR HIRE CORPORATION
PHONE: 800-878-7305 FAX: 708-430-3536
www.lgh-usa.com
12 TON GEAR TROLLEY
CHESTER PT



TROLLEY DIMENSIONS (in.)

A	B	C	D	F	G	H	J	M	N	O	P	R	S	H'
23.75"	12"	1.12"	9.75"	4.5"	13.25"	7"	1.18"	.87"	2"	5"	9.25"	2.5"	1"	14.12"

TROLLEY SPECIFICATIONS

Rated Load (lbs.) 24000	Weight with (lbs.) 525#	Standard Trolley Flange Adj. 5" - 8"	Min. Radius Curve 72"	Pull Chain to move Capacity Load 50 lbs
--------------------------------------	--------------------------------------	---	------------------------------------	--