

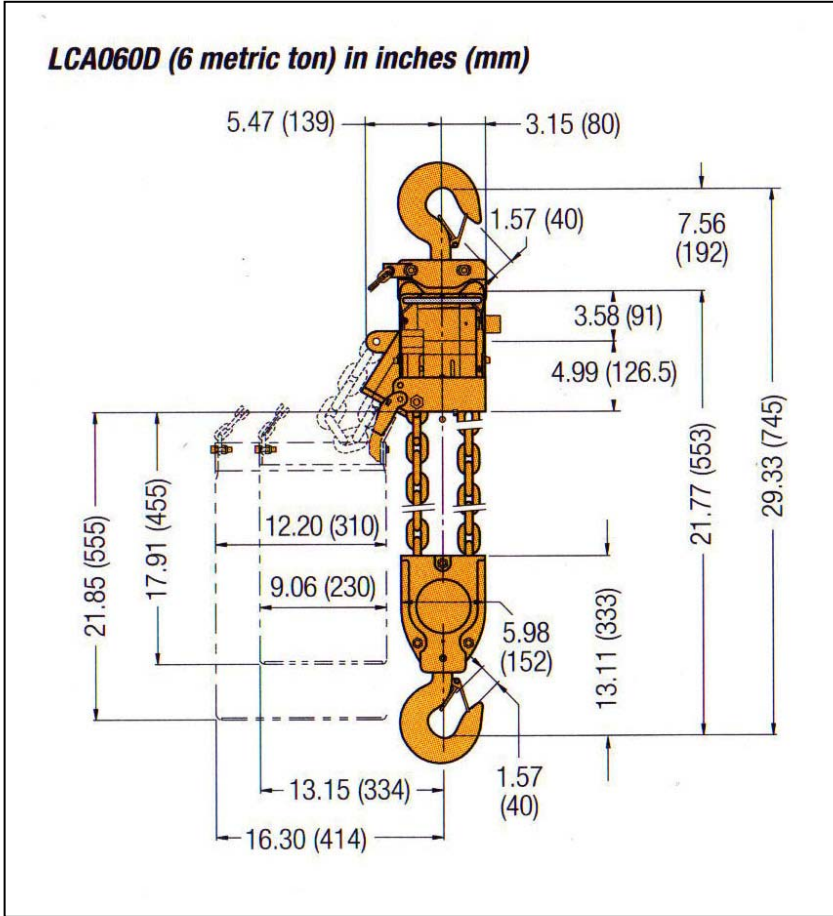

LIFTING GEAR HIRE CORPORATION
PHONE: 800-878-7305 FAX: 708-430-3536
www.lgh-usa.com
6 TON AIR CHAIN HOIST
INGERSOLL-RAND - LCA Model

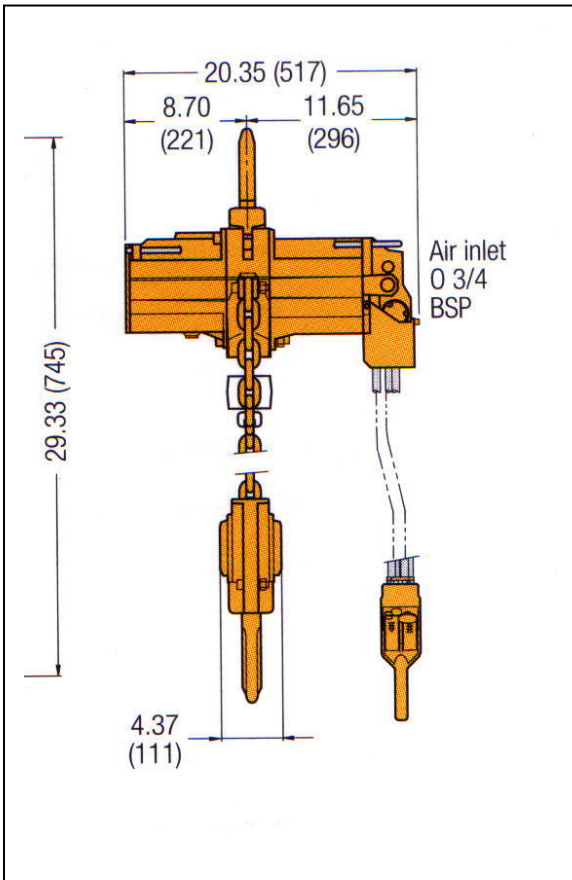

HOIST SPECIFICATIONS

Rated Load
 (lbs.)
 12,000

Weight with
 (10' h.o.l.)
 235#
 (6.0 lbs. per extra foot h.o.l.)

Minimum Distance
 Between Hooks (in.)
 29.33"

No. of Load
 Chain / Size
 2 / 13 X 36 mm

Air Consumption at rated Load (CFM)
 Average
 124

Lifting Speed
 Rated Load
 5.2 fpm

Lowering Speed
 Rated Load
 11.5 fpm