



# Lifting Gear Hire Corporation

P: 800.878.7305 | F: 708-430-3536 | www.lgh-usa.com | sales@lgh-usa.com

## 37.5 Ton Air Chain Hoist

J.D. Neuhaus 37 TI New Model Profi Series

Technical Data		
Model		37 TI
Air pressure	PSI Bar	85 6
Capacity	mt	37.5
Number of chain strands		3
Motor output	kW	6.3
Lifting speed without load	ft/min	5.6
	m/min	1.7
Lifting speed at full load	ft/min	2.5
	m/min	.75
Lowering speed at full load	ft/min	6.6
	m/min	2.0
Air consumption at full load – lifting	cfm	230
	m <sup>3</sup> /min	6.5
Air consumption at full load – lowering	cfm	102
	m <sup>3</sup> /min	2.9
Air connection	inch	G 1 1/2
Hose dimension (Ø inside)	mm	35
Weight with standard lift	lbs	1,874
	kg	850
Chain dimension	mm	23.5 x 66
Weight of 1 m (3.28 ft) chain	lbs/ft	8.2
	kg/m	12.2
Standard lift	ft	10
	m	3
Length of control at standard lift	ft	6.5
	m	2
Sound level at full load <sup>1</sup> – lifting	dB(A)	78
Sound level at full load <sup>1</sup> – lowering	dB(A)	82



50 TI Air Chain Hoist pictured

Dimensions		
Model		37 TI
A minimum headroom <sup>1</sup>	inch	57.9
	mm	1,470
B	inch	36.8
	mm	935
C	inch	21.3
	mm	540
D	inch	42.5
	mm	1,080
E1	inch	3.9
	mm	100
E2	inch	3.9
	mm	100
F	inch	11.2
	mm	285
G maximum width	inch	17.7
	mm	450

<sup>1</sup> Chain containers increase the headroom.

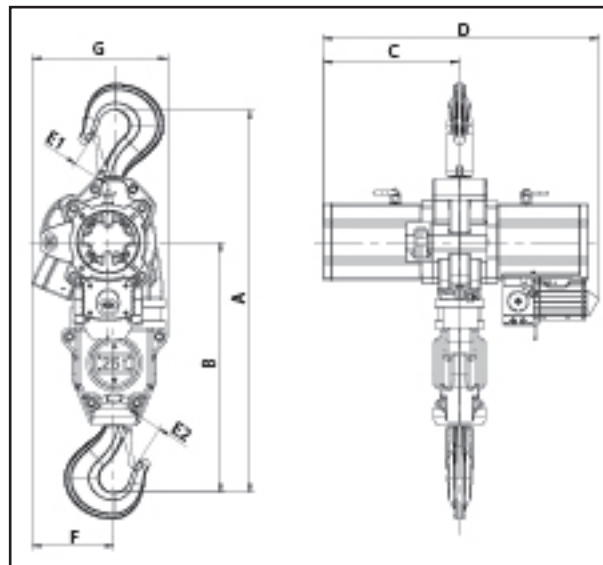

37 TI uses 3 chain strands