

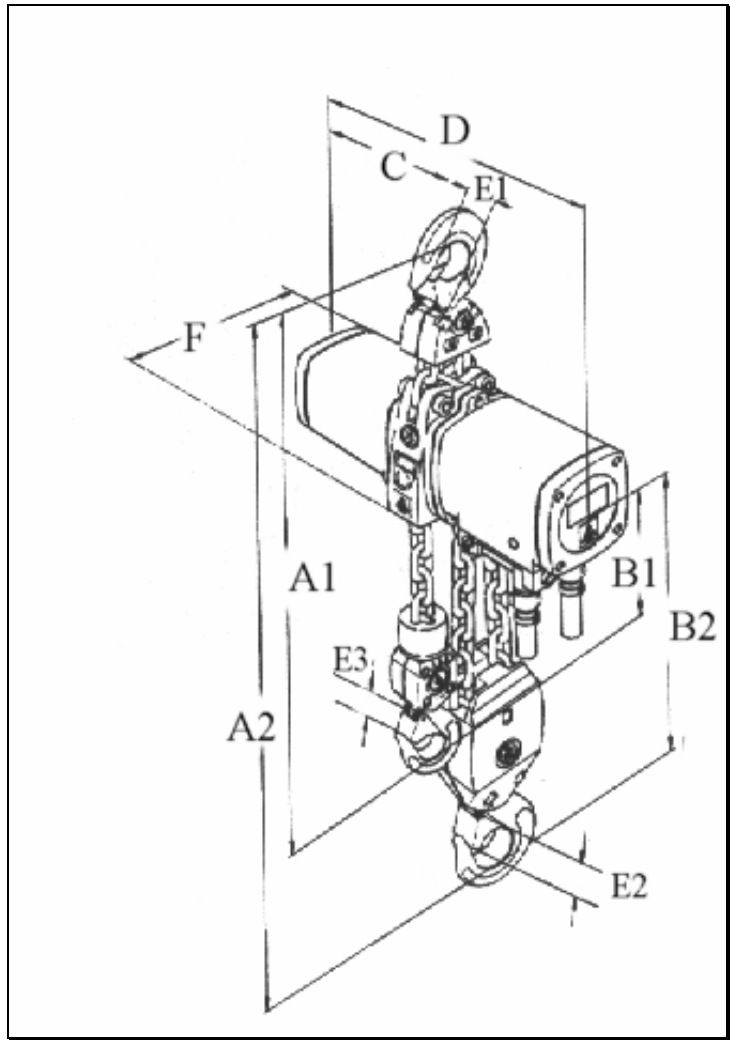

LIFTING GEAR HIRE CORPORATION

PHONE: 800-878-7305
FAX: 708-430-3536
www.lgh-usa.com

1.6 / 3.2 TON
AIR CHAIN
HOIST
J.D. NEUHAUS
B 24



HOIST DIMENSIONS (in.)

A1	A2	B1	B2	C	D	E1	E2	E3	F	No. of load chain / Size
23.9"	25.6"	12.2"	13.9"	9.06"	18.3"	1.1"	1.1"	1.1"	5.75"	1 or 2 / 9 X 27 mm

HOIST SPECIFICATIONS

Rated Load (ton)	Weight with (10' h.o.l.)	Minimum Distance Between Hooks (in.)
1.6 or 3.2	156# (1.2 lbs. per extra foot h.o.l.)	23.9" / 25.6"

Air Consumption at rated Load (CFM)

Lifting	Lowering
60	NA

Lifting Speed

Rated Load	Without Load
11.5 / 5.7 fpm	26.3 / 13.1 fpm

Lowering Speed

Rated Load
29.5 / 14.7 fpm