

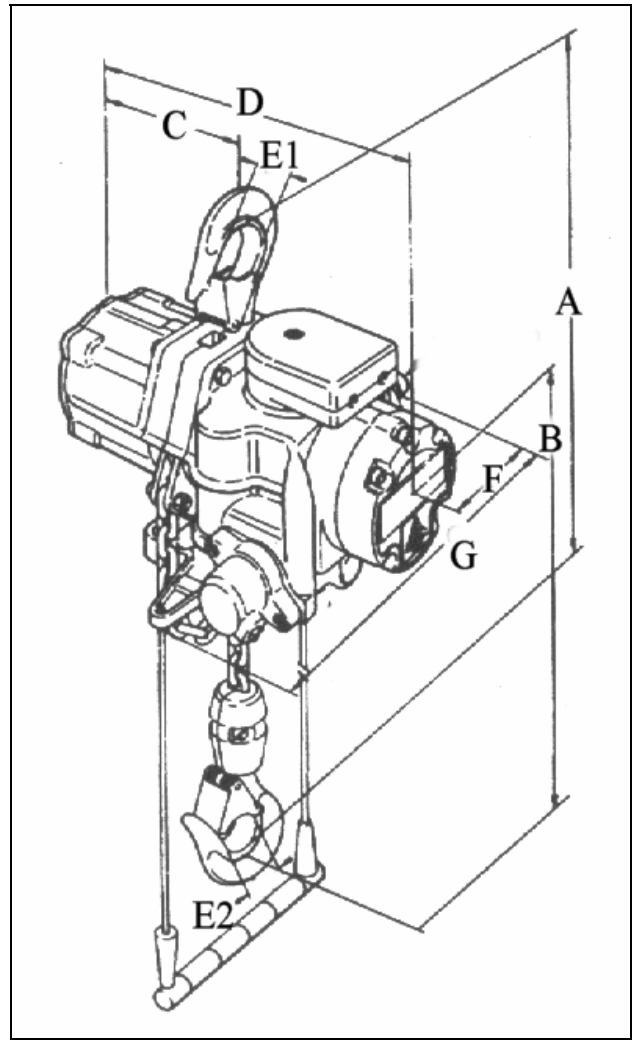

**LIFTING GEAR HIRE CORPORATION**

**PHONE: 800-878-7305**  
**FAX: 708-430-3536**  
**www.lgh-usa.com**

**2 TON**  
**AIR CHAIN**  
**HOIST**  
**J.D. NEUHAUS**  
**2TS**



**HOIST DIMENSIONS (in.)**

A	B	C	D	E1	E2	F	G	No. of load chain / Size
21.4"	14.6"	7.2"	13.7"	1.2"	1.2"	4.6"	8.5"	2 / 7 X 21 mm

**HOIST SPECIFICATIONS**

Rated Load (lbs.)	Weight with (10' h.o.l.)	Minimum Distance Between Hooks (in.)
4,000	63.8# (1.34 lbs. per extra foot h.o.l.)	21.4"

Air Consumption at rated Load (CFM)

Lifting	Lowering
49.6	42.5

Lifting Speed

Rated Load	Without Load
8.0 fpm	19.5 fpm

Lowering Speed

Rated Load
19.5 fpm