

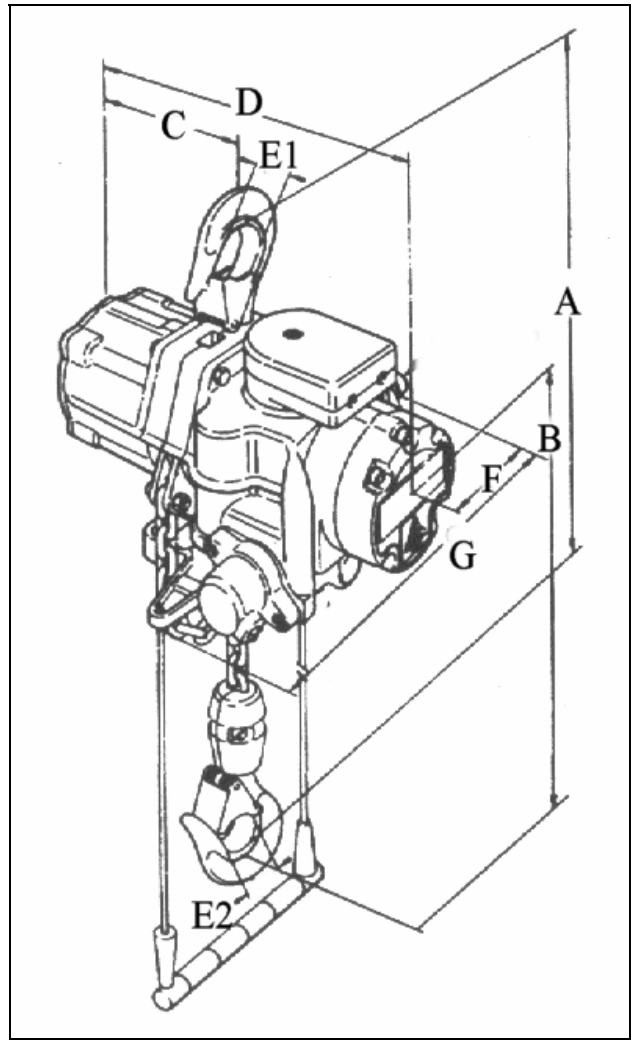

LIFTING GEAR HIRE CORPORATION

PHONE: 800-878-7305
FAX: 708-430-3536
www.lgh-usa.com

25 TON
AIR CHAIN
HOIST
J.D. NEUHAUS
25TI



HOIST DIMENSIONS (in.)

A	B	C	D	E1	E2	F	G	No. of load chain / Size
51.0"	37.9"	15.5"	33.0"	2.9"	2.9"	5.7"	24.0"	2 / 22 X 66 mm

HOIST SPECIFICATIONS

Rated Load (lbs.)	Weight with (10' h.o.l.)	Minimum Distance Between Hooks (in.)
50,000	1025# (14.5 lbs per extra foot h.o.l.)	51.0"

Air Consumption at rated Load (CFM)

Lifting	Lowering
177	212

Lifting Speed

Rated Load	Without Load
3.3 fpm	5.9 fpm

Lowering Speed

Rated Load
6.88 fpm