

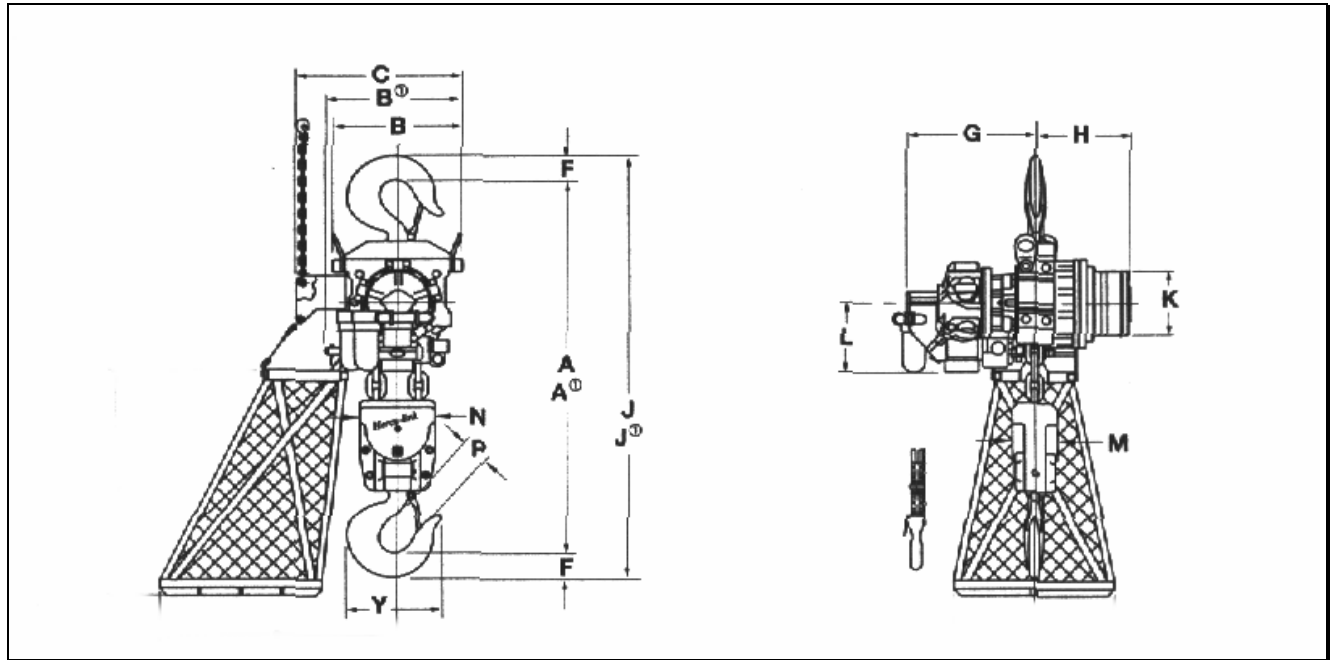

LIFTING GEAR HIRE CORPORATION
PHONE: 800-878-7305 FAX: 708-430-3536
www.lgh-usa.com
20 TON AIR CHAIN HOIST
INGERSOLL-RAND HA1-020 "Hercu-link"



HOIST DIMENSIONS (in.)

<u>A</u>	<u>B</u>	<u>C</u>	<u>F</u>	<u>G</u>	<u>H</u>	<u>J</u>	<u>K</u>	<u>L</u>	<u>M</u>	<u>N</u>	<u>P</u>	<u>Y</u>
42.5"	13.0"	-	3.6"	21.3"	16.8"	49.8"	7.8"	5.0"	9.4"	8.5"	4.0"	13.6"

HOIST SPECIFICATIONS

Rated Load (lbs.) 40,000	Weight with (10' h.o.l.) 1020# (20 lbs. per extra foot h.o.l.)	Minimum Distance Between Hooks (in.) 42.50"	No. of Load Chain / Size 4 / 16 X 36 mm
--------------------------------	---	---	---

Air Consumption at rated Load (CFM)
 Average
 165

Lifting Speed
 Rated Load
 2.5 fpm

Lowering Speed
 Rated Load
 3 fpm