

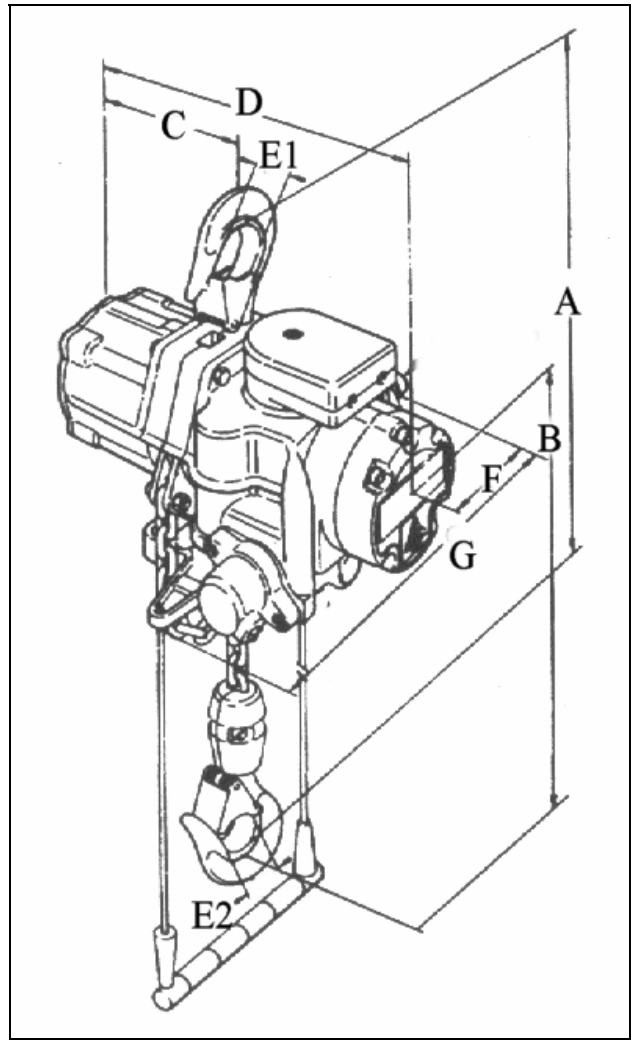

**LIFTING GEAR HIRE CORPORATION**

**PHONE: 800-878-7305**  
**FAX: 708-430-3536**  
**www.lgh-usa.com**

**20 TON**  
**AIR CHAIN**  
**HOIST**  
**J.D. NEUHAUS**  
**20TI**



**HOIST DIMENSIONS (in.)**

A	B	C	D	E1	E2	F	G	No. of load chain / Size
42.9"	27.9"	15.4"	30.2"	2.9"	2.9"	4.3"	14.2"	4 / 16 X 45 mm

**HOIST SPECIFICATIONS**

Rated Load (lbs.)	Weight with (10' h.o.l.)	Minimum Distance Between Hooks (in.)
40,000	627#	42.9"
( 16 lbs. per extra foot h.o.l.)		

Air Consumption at rated Load (CFM)  
 Lifting  
 102

Lifting Speed  
 Rated Load | Without Load  
 1.6 fpm | 3.2 fpm

Lowering Speed  
 Rated Load  
 4.26 fpm