

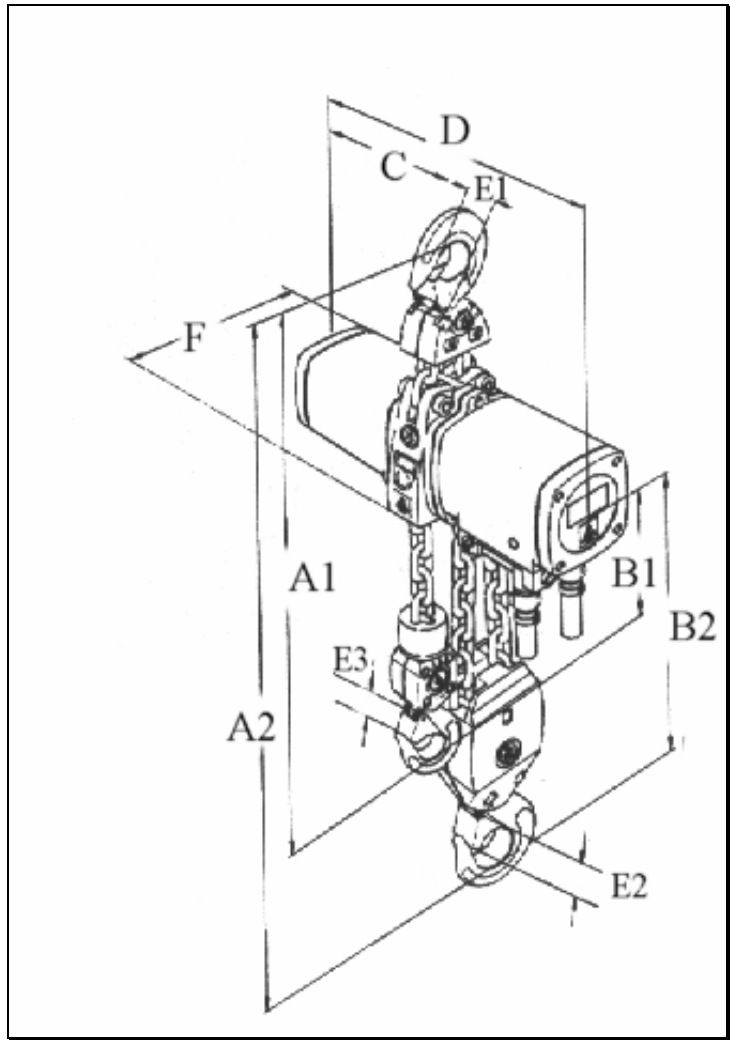

LIFTING GEAR HIRE CORPORATION

PHONE: 800-878-7305
FAX: 708-430-3536
www.lgh-usa.com

1 OR 2 TON
AIR CHAIN
HOIST
J.D. NEUHAUS
M 64



HOIST DIMENSIONS (in.)

| A1 | A2 | B1 | B2 | C | D | E1 | E2 | E3 | F | No. of load chain / Size |
|-------|-------|------|-------|------|-------|------|------|------|------|--------------------------|
| 23.7" | 26.0" | 5.6" | 14.6" | 6.9" | 14.8" | 1.2" | 1.2" | 1.2" | 5.3" | 1 or 2 / 9 X 27 mm |

HOIST SPECIFICATIONS

| Rated Load (ton) | Weight with (10' h.o.l.) | Minimum Distance Between Hooks (in.) |
|---------------------|-------------------------------------------|-----------------------------------------|
| 1 or 2 | 92.4# (1.2 lbs per extra foot h.o.l.) | 23.7" or 26" |

Air Consumption at rated Load (CFM)

| Lifting | Lowering |
|---------|----------|
| 35.4 | NA |

Lifting Speed

| Rated Load | Without Load |
|--------------|--------------|
| 15 / 7.5 fpm | 26 / 13 fpm |

Lowering Speed

| Rated Load |
|---------------|
| 39 / 19.5 fpm |