

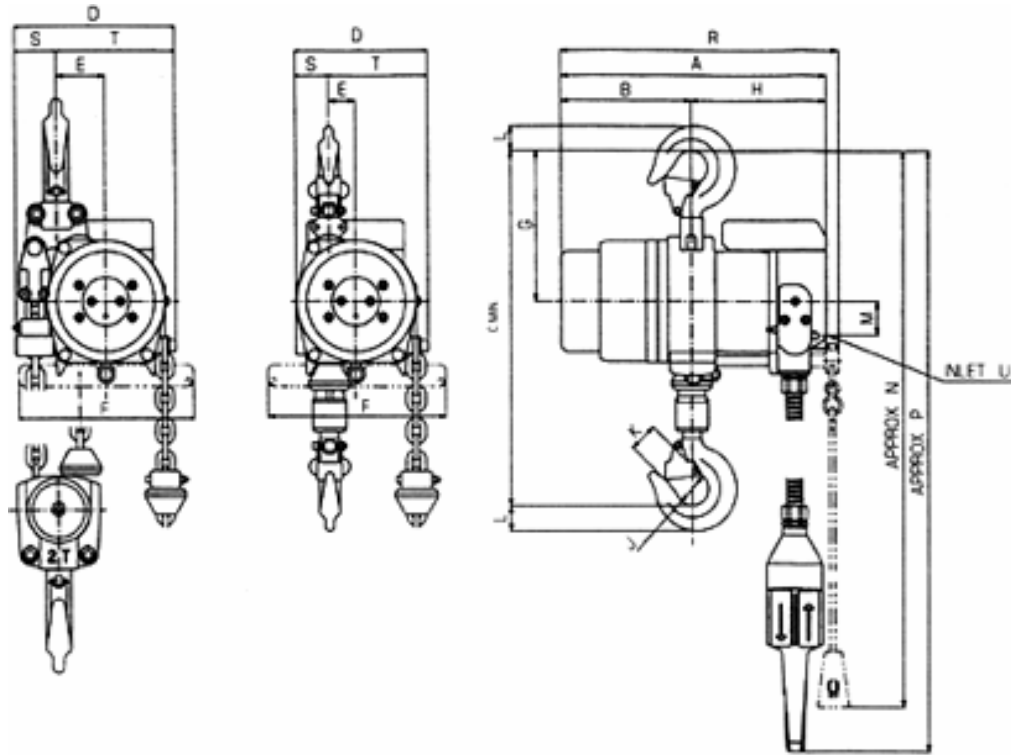

LIFTING GEAR HIRE CORPORATION
 PHONE: 800-878-7305 FAX: 708-430-3536
 www.lgh-usa.com
1 TON AIR CHAIN HOIST
 HARRINGTON – TCR Model



HOIST DIMENSIONS (in.)

A	B	C	D	E	F	G	H	J	K	L	M	N	P	R	S	T
12.5"	6.1"	16.4"	6.2"	1.3"	8.3"	7.0"	6.5"	1.6"	1.3"	1.1"	1.5"	6.1"	-	14.0"	1.5"	4.6"

HOIST SPECIFICATIONS

Rated Load lbs.) 2,000	Weight with (10' h.o.l.) 75# (.75 lbs. per extra foot h.o.l.)	Minimum Distance Between Hooks (in.) 16.4"	No. of load chain / Size 1 / 7.1 X 21.0 mm
------------------------------	--	--	---

<u>Air Consumption at rated Load (CFM)</u>	
Lifting	Lowering
53	60

<u>Lifting Speed</u>	
Rated Load	Without Load
19.5 fpm	37.0 fpm

<u>Lowering Speed</u>
Rated Load
34.0 fpm