

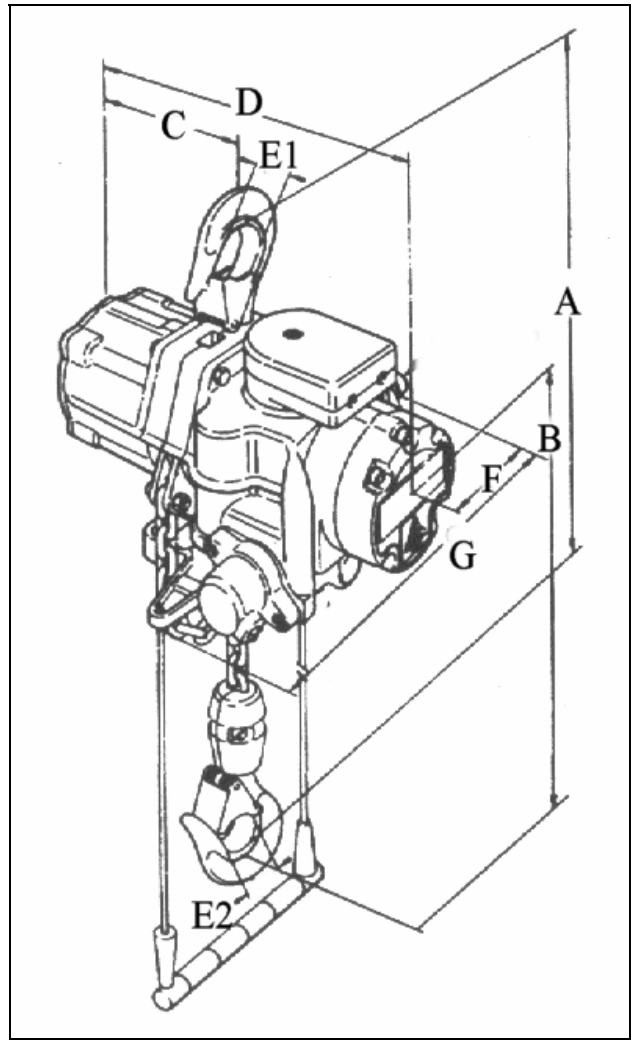

LIFTING GEAR HIRE CORPORATION

PHONE: 800-878-7305
FAX: 708-430-3536
www.lgh-usa.com

1 TON
AIR CHAIN
HOIST
J.D. NEUHAUS
1TS



HOIST DIMENSIONS (in.)

A	B	C	D	E1	E2	F	G	No. of load chain / Size
18.6"	11.7"	7.2"	13.7"	1.2"	1.0"	5.6"	8.5"	1 / 7 X 21 mm

HOIST SPECIFICATIONS

Rated Load (lbs.)	Weight with (10' h.o.l.)	Minimum Distance Between Hooks (in.)
2000	52.8#	18.6"
(.67 lbs per extra foot h.o.l.)		

Air Consumption at rated Load (CFM)

Lifting	Lowering
49.6	42.5

Lifting Speed

Rated Load	Without Load
16.0 fpm	39.3 fpm

Lowering Speed

Rated Load
39.3 fpm