

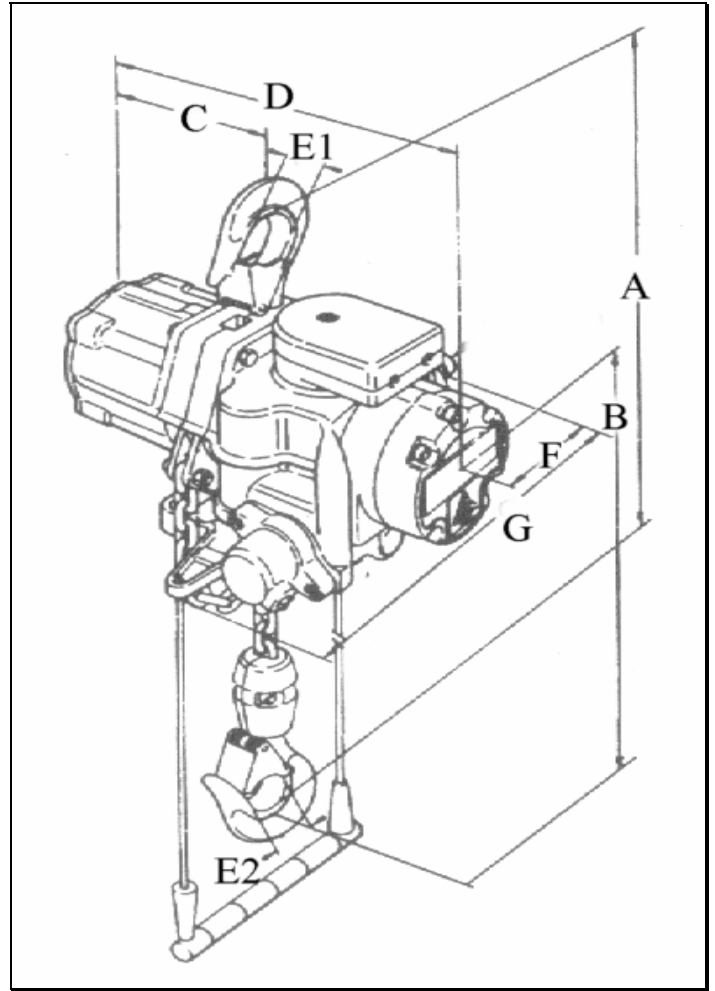

LIFTING GEAR HIRE CORPORATION

PHONE: 800-878-7305
FAX: 708-430-3536
www.lgh-usa.com

1/2 TON
AIR CHAIN
HOIST
J.D. NEUHAUS
05TS



HOIST DIMENSIONS (in.)

A	B	C	D	E1	E2	F	G	No. of load chain / Size
17.9"	11.7"	5.7"	12.1"	1.0"	1.0"	5.4"	8.5"	1 / 7 X 21 mm

HOIST SPECIFICATIONS

Rated Load (lbs.)	Weight with (10' h.o.l.)	Minimum Distance Between Hooks (in.)
1000	46.2#	17.9"
(.67 lbs per extra foot h.o.l.)		

<u>Air Consumption at rated Load (CFM)</u>	
Lifting	Lowering
49.6	42.5

<u>Lifting Speed</u>	
Rated Load	Without Load
32.5 fpm	78.5 fpm

<u>Lowering Speed</u>
Rated Load
24.0 fpm