

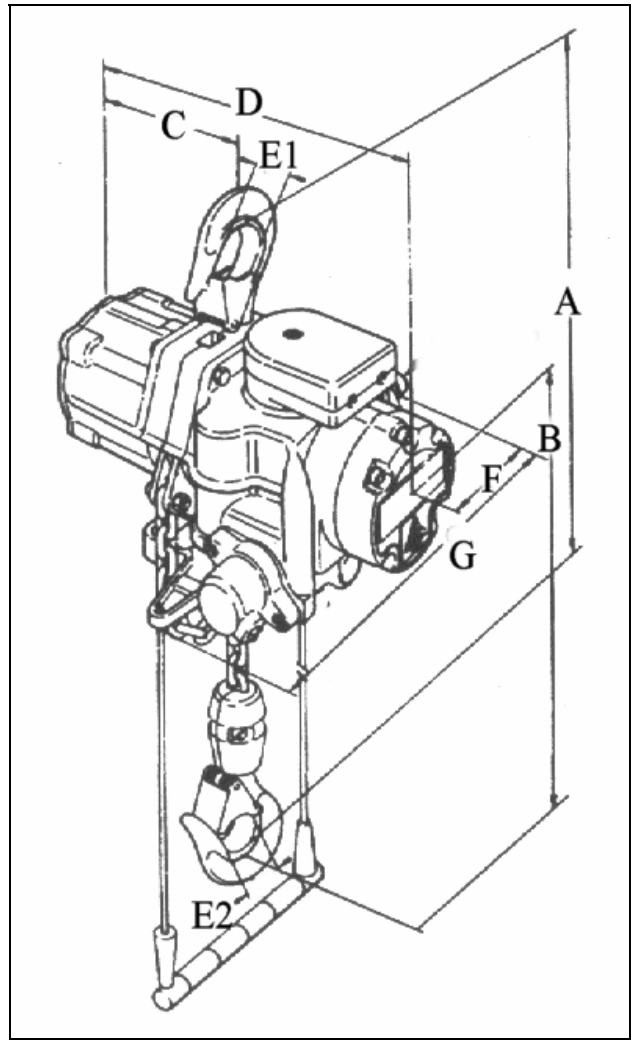

LIFTING GEAR HIRE CORPORATION

PHONE: 800-878-7305
FAX: 708-430-3536
www.lgh-usa.com

15 TON
AIR CHAIN
HOIST
J.D. NEUHAUS
15TI



HOIST DIMENSIONS (in.)

A	B	C	D	E1	E2	F	G	No. of load chain / Size
35.0"	23.0"	9.4"	20.8"	2.2"	2.2"	5.6"	18.3"	3 / 16 X 45 mm

HOIST SPECIFICATIONS

Rated Load (lbs.)	Weight with (10' h.o.l.)	Minimum Distance Between Hooks (in.)
30000	413.6#	35.0"
(11.7 lbs per extra foot h.o.l.)		

Air Consumption at rated Load (CFM)

Lifting	Lowering
85.0	110.0

Lifting Speed

Rated Load	Without Load
2.3 fpm	5.6 fpm

Lowering Speed

Rated Load
6.55 fpm