

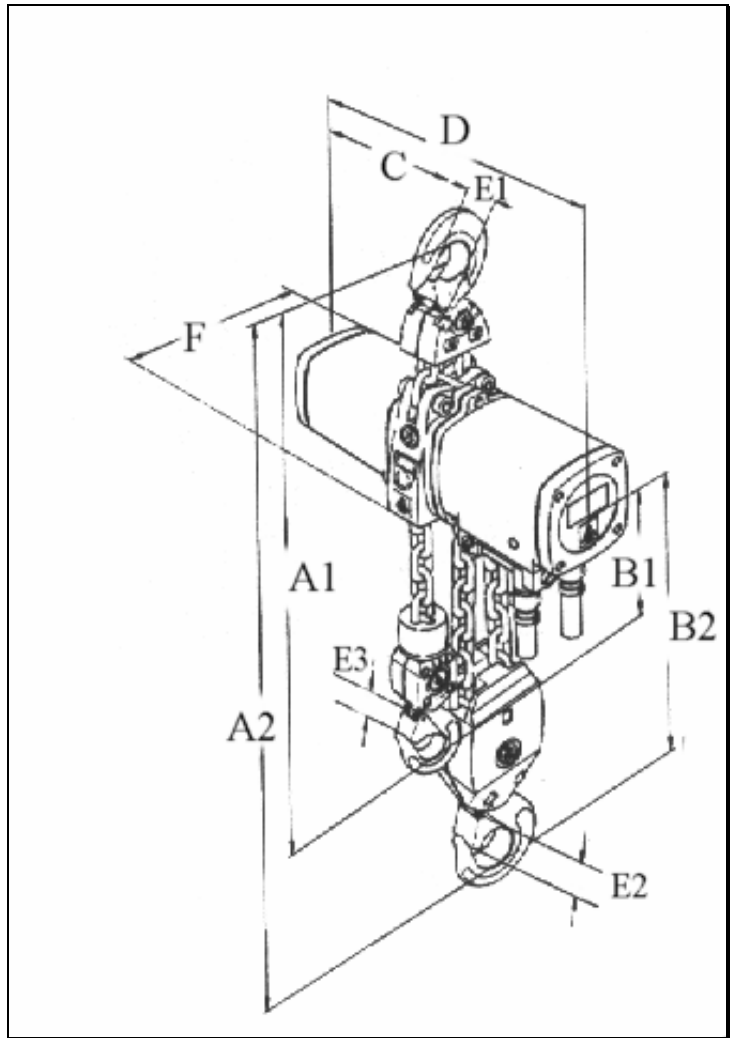

LIFTING GEAR HIRE CORPORATION

PHONE: 800-878-7305
FAX: 708-430-3536
www.lgh-usa.com

12 TON
AIR CHAIN
HOIST
J.D. NEUHAUS
M 77



HOIST DIMENSIONS (in.)

A1	A2	B1	B2	C	D	E1	E2	E3	F	No. of load chain / Size
45.3"	45.3"	7.2"	7.2"	14.8"	29"	1.7"	1.7"	1.7"	13.8"	1 / 22 X 66 mm

HOIST SPECIFICATIONS

Rated Load (ton)	Weight with (10' h.o.l.) 559# (7.25 lbs per extra foot h.o.l.)	Minimum Distance Between Hooks (in.) 45.3"
12		

Air Consumption at rated Load (CFM)

Lifting	Lowering
110	NA

Lifting Speed

Rated Load	Without Load
4.0 / 4.0 fpm	8.8 / 8.8 fpm

Lowering Speed

Rated Load
13 / 13 fpm